

INSTALLATION AND PROGRAMMING GUIDE

9750

HARDWIRED CONTROL PANEL

9750 Hardwired Control Panel Installation and Programming Guide.

© Cooper Security Limited. 2000

Every effort has been made to ensure that the contents of this book are correct, errors and omissions excepted. However, neither the authors nor Cooper Security Limited accept any liability for loss or damage caused or alleged to be caused directly or indirectly by this book. The contents of this book are subject to change without notice.

Printed and published in the U.K.

Contents

1. INTRODUCTION	1
Operator Controls and Displays - 9930	3
Operator Controls and Displays - 9925	4
System Features	5
Detectors	5
9755 Hardwired Expander	5
9955 Radio Expander	5
User Control	6
2. Technical Description	7
Specification	7
Power Supply	7
Outputs	7
Inputs	7
Fuses	7
Control Unit PCB and Case	8
9755 Expander	9
Compatible Equipment	10
3. INSTALLATION	11
Fitting the System	11
Fitting the Control unit Case	11
Fitting the Control Unit PCB	11
Fitting a 9930 LCD Keypad	12
Fitting a Remote 9925 Arming Station	13
Wiring the Control Unit	14
Cable Entries	14
Mains Connection	14
Remote Keypads	15
Keypad Addressing	15
Keypad Backlight	15
Connecting Keypads	16
Exit Terminate Button	16
Sounders	16
Detector Circuit Connections	17
Four Wire CC Connections	17
Connecting a 9755 Expander	17
Using Programmable Outputs	18
Wiring Keyswitches	19
Momentary or Continuous Keyswitches	19
Installing a Communicator	20
Built in Communicator	20
Telephone Line	20
Three Way Calling	20
Line Monitoring	20
Statutory Information	21
Application	21
Compatible PABXs	21
Approval	21
REN	22
Safety Notice	22
Connecting the Telephone Line	23
Fitting a Plug-by Communicator	24
Fitting a Battery	26
Initial Start Up	27

4. Programming	29
Entering Programming Mode	29
Programming Commands	29
Communications Programming	34
Leaving Programming Mode	36
Engineer Reset	36
Re-entering Programming Mode	36
Restoring the Access Codes (1st stage reset)	36
Restoring All Factory Default Programming	37
Programming Reference	37
Zone Programming (Commands 01 to 16)	37
Zone Types	37
Zone Attributes	38
Change Engineer Code (Command 20)	40
Loudspeaker Chime (Command 22)	40
RedCare Reset (Command 23)	40
Continuous Sounder (Command 25)	40
Local Sounder Delay on Entry (Command 26)	41
Exit Fault External Sounders (Command 27)	41
Status Display (Command 28)	41
Silent or Audible PA (Command 30)	41
System Reset (Command 33)	41
PA Reset (Command 34)	42
First Circuit Response (Command 35)	42
Alarm Abort (Command 36)	42
Daytime Tamper Communication (Command 37)	42
Level A Exit Mode (Command 39)	42
System Auto Re-Arm (Command 40)	43
Bell Delay (Command 41)	43
Bell Duration (Command 42)	43
Level A Entry Time (Command 43)	43
Level A Exit Time (Command 44)	43
Entry/Exit Tone Volume (Command 45)	43
CSID Code (Command 50)	44
Setting Time and Date (Command 51)	44
Abort Reset (Command 53)	45
Level B Final Exit Response (Command 60)	45
Level B Entry Route Response (Command 61)	45
Level B Exit Mode (Command 62)	45
Level B Alarm Response (Command 63)	45
Level B Entry Time (Command 64)	45
Level B Exit Time (Command 65)	46
Output Programming (Commands 81, 82 and 83)	46
Output Type	46
Dual Ply Entry Warning (Command 86)	47
Keypad Dual Key PA (Command 87)	47
Alarm Confirmation (Command 89)	47
Commands 90 - 97, See "5.Testing"	47
Load Full Defaults (Command 98)	48
Leave Programming Mode (Command 99)	48
Call Mode (Command 101)	48
Reporting Type (Command 103)	49
Line Fail Response (Command 106)	49
Line Integrity Checking (Command 107)	50
Dynamic Test (Command 108)	50
Three Way Call - UK only (Command 109)	50
Download Mode (Command 110)	51
Rings to Answer (Command 112)	51
Answer on One Ring (Command 113)	51

Access Mode (Command 114)	52
Communicator Telephone Numbers (Command 115/116)	52
Account Number (Command 117)	53
Downloader Telephone Numbers (Commands 118/119)	53
Fast Format Channels (Command 121)	54
Report Restorals (Command 123)	54
Country Defaults (Command 126)	54
Report Mode (Command 131)	54
Modem Tone Format (Command 132)	56
Contact ID Options (Command 143)	56
5. Testing	57
Reading the Log (Command 90)	57
Keypad and Event Log Displays	57
Engineer Walk Test (Command 97)	59
Index	61

1. INTRODUCTION

The 9750 is designed to be fully programmable to suit individual site requirements and user needs.

The system comprises a control unit in a metal case, up to four separate keypads and one keyswitch interfaces (see Figure 1 on the next page). You should always fit at least one keypad.

The control unit provides:

- A four-wire bus connection for keypads, keyswitches and hardwired or wireless zone expanders.
- Connections for eight Closed Circuit zones.
- Connections for three fully programmable outputs.
- Internal sounder loudspeaker output with electronically generated Chime, Alarm, Fire and Entry/Exit tones. (The volume of the Entry/Exit and Chime tones can be adjusted).
- Built in communicator.
- Remote up/downloading.
- Pins for fitting a plug-by communication device.

A separate **9755** expander unit allows connection of a further eight wired zones. Alternatively, a **9955** expander allows connection of eight wirefree zones.

The control unit supports two types of keypad: the **9930** sixteen character Liquid Crystal Display (LCD), or the **9925** arming station. In addition the control unit also supports the **9928** keyswitch interface.

As an Installer you can program the system either from the keypads, or remotely using PC based Windows <Downloader>. When programming from the keypads the programming interface is arranged as a set of three-digit numbered commands similar to those used by the 9800 family of products.

The system can provide for up to 8 separate users. User facilities include:

- Two different security levels (full set and part set) which can be programmed by the Installer.
- User programmable Duress code.
- Keyswitch setting/unsetting.
- Dual key PA alarm from the keypads.
- Remote telecommand set/unset when using 9955 RF Expander.

To reduce the possibility of false alarms the system also provides Alarm Abort and Alarm Confirmation communications output.

1. Introduction

Before attempting to program the system, make sure you are completely familiar with the functions of the system and its programmable options.

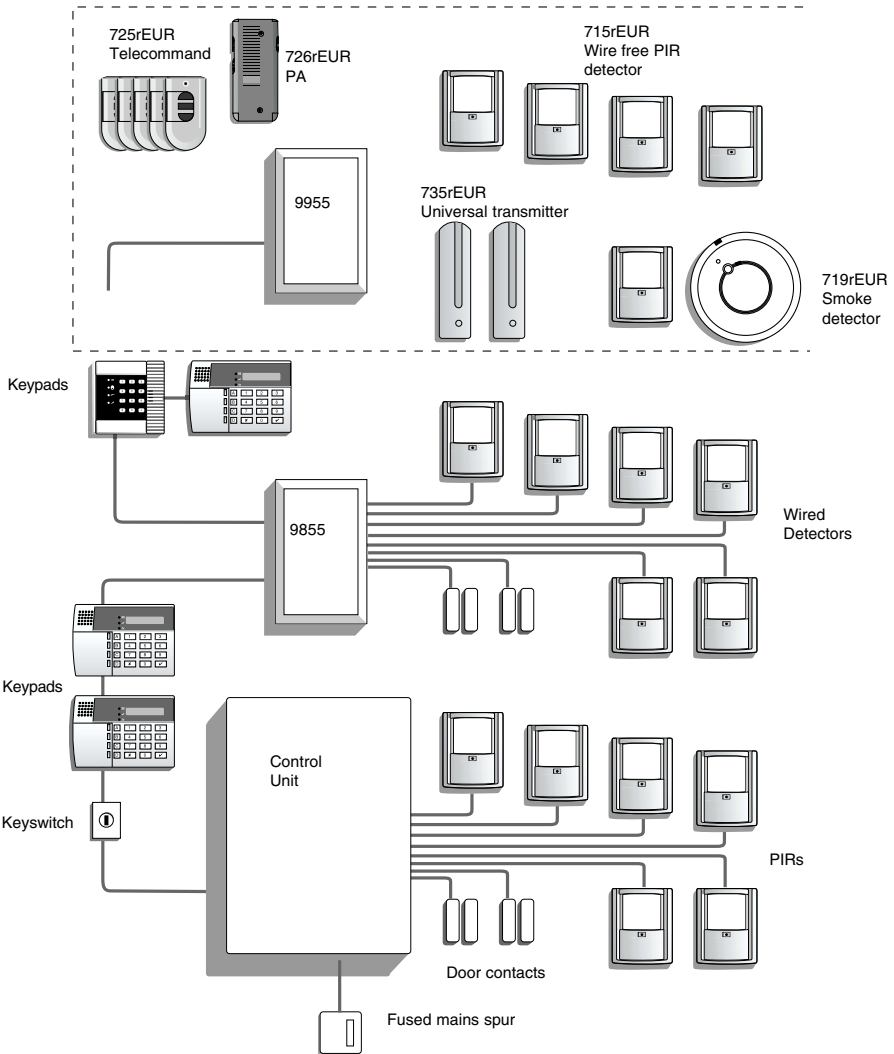

Figure 1. 9750 System Layout

Operator Controls and Displays - 9930

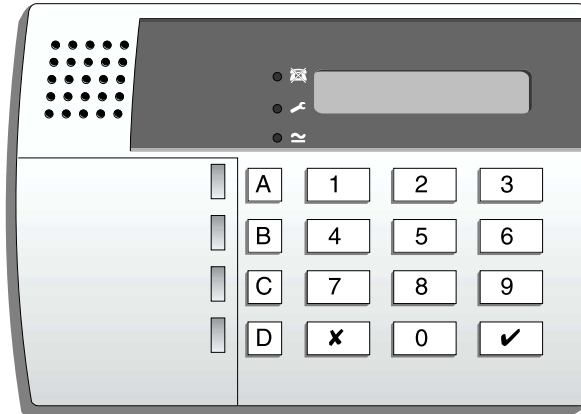

Figure 2. 9930 Remote Keypad.

The 9930 keypad has a single line 16 character LCD display that shows first to alarm information, level status, and programming commands. In addition there are three LEDs with the following functions:

- ⌚ Glows steadily when mains power is present. Flashes when the system is working from battery backup.
- 📞 Glows steadily if a telephone line fault is present.
- 🔑 Glows steadily if:
 - a) A PA, Fire, 24 hour or tamper circuit is active while the system is unset.
 - b) The system needs an engineer or remote reset.
 - c) A telephone line fault is present.

The LCD keypad provides the following keys:

- 9 Used to start a test of the detectors.
- 8 Used to start a test of the sounders and strobe.
- 7 Used to enable or disable the Chime facility.
- 6 Used to set the internal clock calendar, which provides a time stamp on printed log entries.
- 5 Used to display the log (250 events).
- 4 Used to change the user access codes.
- ✓ Used to enter programming and setting/unsetting commands.
- ✗ Used to set the system with individual zones temporarily omitted.
- A, B Level setting keys. Level A sets the whole system.

Operator Controls and Displays - 9925

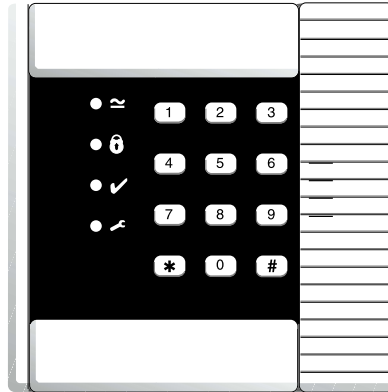







Figure 3. 9925 Arming Station.

The 9925 arming station is intended for use solely in setting and unsetting the system. The 9925 has the following LEDs:

-  Glows steadily when mains power is present. Flashes when the system is working from battery backup.
-  Glows steadily if:
 - a) A PA, Fire, 24 hour or tamper circuit is active while the system is unset.
 - b) The system needs an engineer or remote reset.
 - c) A telephone line fault is present.
-  Glows steadily when the system is set. Note that you can program the system to extinguish the  lamp three minutes after the system sets (see Command 28 in "4. Programming").
-  Glows when the system is ready to set.

The 9925 has the same number keys as the LCD keypad. However the 9925 does not have the A and B Level setting keys, and uses * and # in place of X and ✓.

System Features

Detectors

The control unit provides connections for up to eight separate detector **zones**. Each zone can be connected as a four-wire closed circuit loop (CCL). See "4. Programming - Programming Commands" for the factory default settings and instructions on how to change the zone types and attributes.

9755 Hardwired Expander

The 9755 expander provides an extra eight CCL zones to give a total of 16 zones.

9955 Radio Expander

The 9955 Radio Expander allows you to connect up to eight radio detectors. In addition each expander also provides for up to six telecommands or PA transmitters.

The 9955 unit can work with the following devices on 868.6625MHz:

- a) **719r**. A photoelectric smoke chamber type detector.
- b) **715r**. A Passive Infra Red (PIR) movement detector with 15m standard range . This detector has a three minute lockout time after detection, in order to lengthen battery life.
- c) **725r**. A Remote Setting Device (also known as a "telecommand") that can be used to full set, part set or unset the system. The 725rEUR can also be used as a Panic Alarm.
- d) **726r**. A small radio transmitter that can be used to start a PA alarm.
- e) **735r**. A universal transmitter that can be used as a door contact or for connecting hardwired inputs.
- f) **747r**. A Go/No Go test meter that provides a simple method for surveying potential radio sites.
- g) **746r**. A test transmitter used with the 747rEUR for surveying potential user sites.

Each radio detector and remote setting device contains a digital identity code that the RFX unit 'learns' during installation. The code is one of over 16 million possibilities. This ensures that the RFX unit will not respond to any other detectors or remote setting switches apart from the ones it has learned. See "RFX Installation and Programming", part number 496482, for more details.

User Control

The control unit provides eight independent user access codes and a separate Duress code. The user can change these codes at any time, but cannot program the system with these codes.

The user can set the system in the following modes:

- | | |
|---------------|---|
| Full Set | All the zones function as programmed during installation. |
| Part Set B | Selected zones are omitted. You must program the zones to be omitted during installation. |
| Set with Omit | One or more zones temporarily omitted. The user selects the zones to be omitted during setting. |

2. Technical Description

Specification

Operating temperature = -10° to +55°C

Humidity = 96% RH

Dimensions = 243mm W, 234mm H, 87mm D

Weight = 2.45 kg (without stand-by battery)

Conforms to EN50131-1 Grade 1 and current BS4737 Part 1 for remote signalled systems, ACPO-IAS Policy, NACOSS NACP14, ABI log requirements.

Power Supply

System power supply = 230VAC (ambient Temp. 20°. C) 1A total

Control unit power = 50mA nominal quiescent, 150mA active

9930 Remote Keypad = 20mA quiescent with keypad backlight on

Standby Battery = 12 Volt, 7AH rechargeable lead-acid, Gel Type battery (not supplied)

Conforms to EN50131-6 Type A power supply for Grade 1 systems.

Outputs

O/P 1, 2, 3 = open collector transistor outputs, 500mA, 12VDC. negative applied

LS = can support two parallel connected externally mounted 16 Ohm loudspeakers for internal sounder or EE tones.

AUX (for detectors) = 500mA, 12VDC

Coms OP1-5* = 12V logic outputs, -ve applied in alarm (+ve removed).

Inputs

TR = Tamper return for bell.

Tellback/RedCare reset* = +12V applied to operate reset.

LIne Fault input* = +12V applied to indicate line failure.

** These outputs and inputs appear as pins on the connector for the plug by communicator. See "3. Installation - Fitting a Plug by Communicator".*

Fuses

F1 - 12V AUX = 1A Fast

F2 - Battery = 2A Anti Surge

Caution: When replacing fuses use the ratings quoted above.

Control Unit PCB and Case

Figure 4 shows the layout of the control unit PCB.

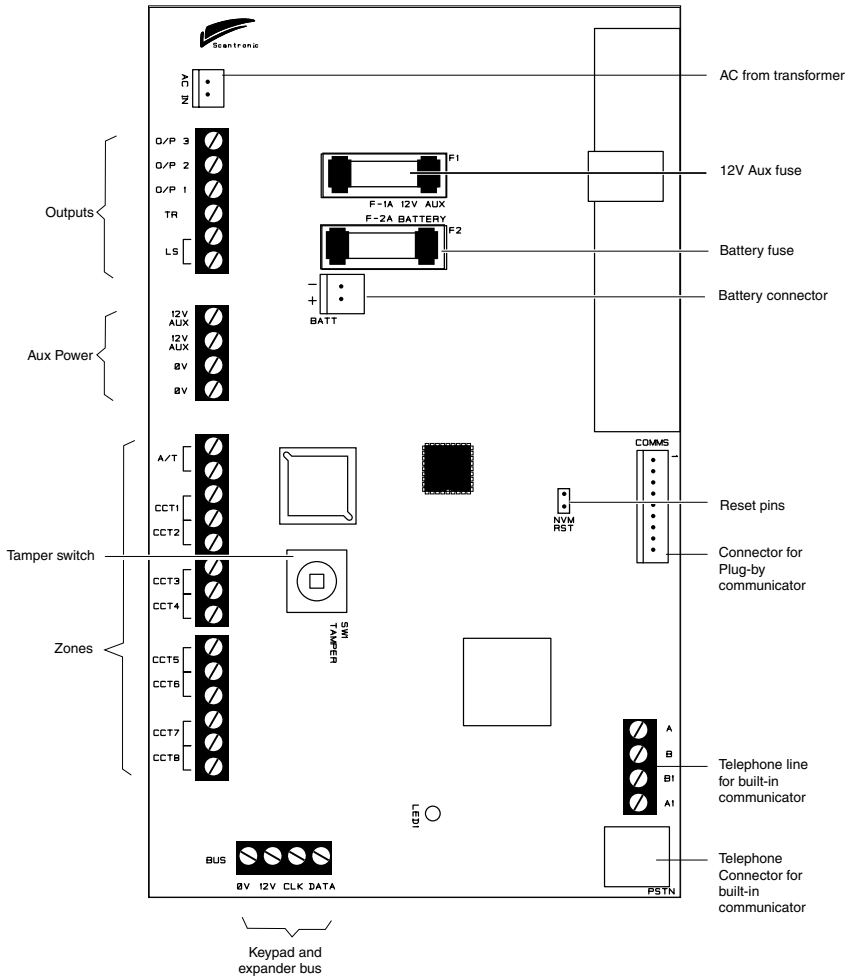

Figure 4. Control Unit PCB Layout

9755 Expander

The 9755 Expander provides connectors for eight four-wire CC loop zones. Figure 5 shows the layout of the PCB.

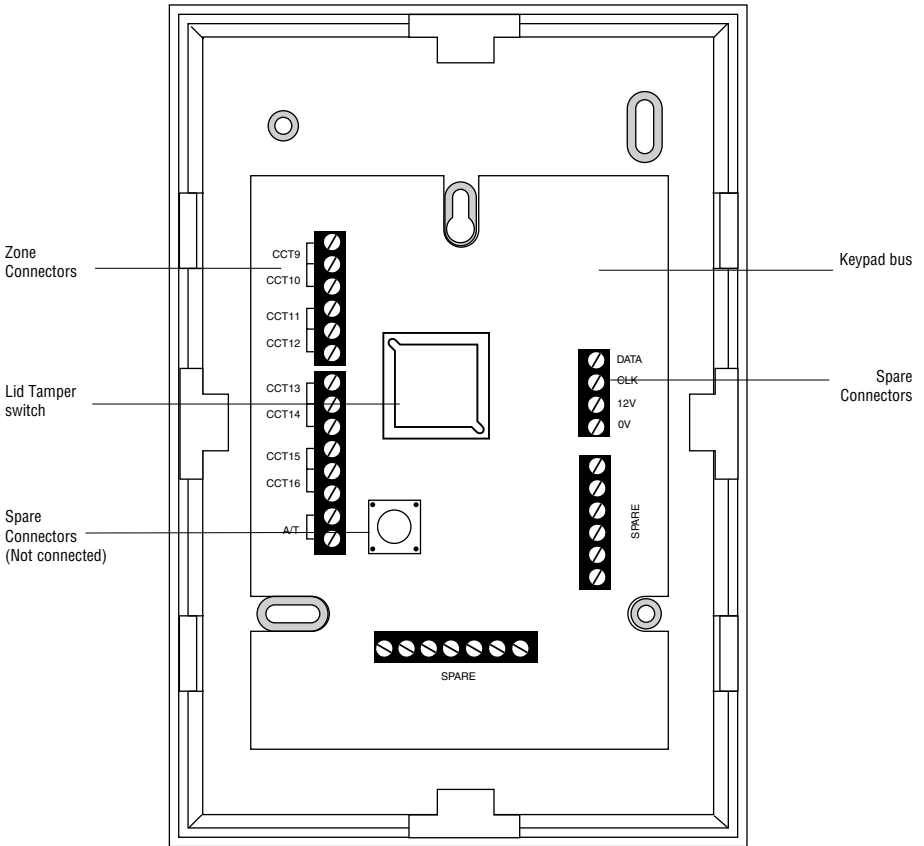

Figure 5. 9750HWX Expander

Compatible Equipment

715rEUR-00	Radio PIR.
719rEUR-00	Radio Smoke Detector.
725rEUR-00	Radio Remote Setting Device.
726rEUR-00	Radio PA.
735rEUR-00	Universal Transmitter.
746rEUR-00	868MHz Test transmitter.
747rEUR-00	868MHz Go/No Go test receiver.
9925EUR-00	Arming Station.
9928EUR-00	Keyswitch interface.
9930EUR-00	LCD Keypad.
9755EUR-00	Hardwired eight zone expander.
9955EUR-00	868MHz "Class VI" radio expander.
956UK-00	Downloader.

3. INSTALLATION

Note: The following instructions assume that you have already run the necessary cabling.

Caution: Always remove mains power before opening the case lid. Do not work inside the control unit with mains power present.

Fitting the System

Fitting the Control unit Case

1. Remove the control unit case from the packing.
2. Remove the front screws and slide off the case lid.
3. The upper part of the case back provides a central keyway. Mark and drill a hole for the keyway. Temporarily fix the case back to the wall. Now mark the position of two more fixing holes, remove the case back and continue to drill the holes.
4. Refit the case back to the wall using not less than 30mm x No 8 Dome or Pan-head screws.

Fitting the Control Unit PCB.

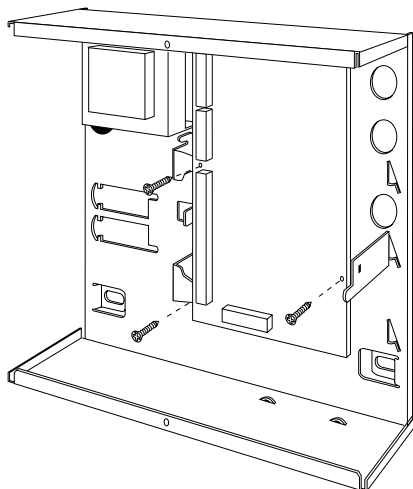

Figure 6. Fitting Control Unit PCB

1. Fit the removable support pillar into the case back.
2. Secure the PCB to the support pillars with the screws provided (Figure

3. Installation

- 6). Make sure that the bottom left corner of the PCB is seated on its support pillar.

Fitting a 9930 LCD Keypad

The backplate of the 9930 LCD keypad contains an adjustable cam that you can use to make sure the tamper switch will operate correctly when the keypad is mounted on an uneven surface. Figure 7 shows the backplate and the position of mounting holes.

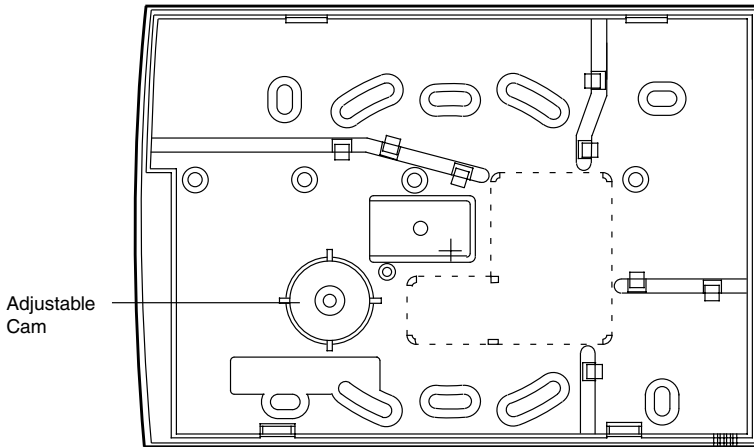

Figure 7. Backplate of the 9930 LCD Keypad

Scantronic recommend that you mount the keypad using No 8 or 6 screws (M4/M3.5) as follows:

1. Select which cable entry you are going to use and break out the appropriate plastic sections.
2. Hold the backplate in place against the wall and mark the position of the centre hole in the adjustable cam (see Figure 7).
3. Drill and plug the hole, and screw the backplate to the wall through the adjustable cam. Do **not** tighten the screw completely home.
4. Make sure the backplate is level and mark, drill and plug at least two other fixing holes. Screw the backplate to the wall through the fixing holes.
5. Cut the plastic webs connecting the cam to the remainder of the base plate.

Note: *If you do not cut the webs then the tamper switch will not operate if the complete keypad is forced off the wall.*

6. Mount the front of the keypad (containing the keypad pcb) onto the backplate and make sure that the tamper switch operates.
7. If the tamper switch does **not** operate then rotate the cam until the tamper switch operates correctly when the front of the keypad is mounted on the backplate.

Fitting a Remote 9925 Arming Station

Figure 8 shows the 9925 Arming Station.

1. If necessary, lift the flaps on the faceplate of the keypad and undo the four screws holding on the back of the case.
2. Hold the keypad back in place and mark, drill and plug the position of keyhole.
3. Mount the keypad back with a single screw through the keyhole.
4. Mark, drill and plug the position of two more mounting holes.
5. Fix the keypad back in place with two more screws.

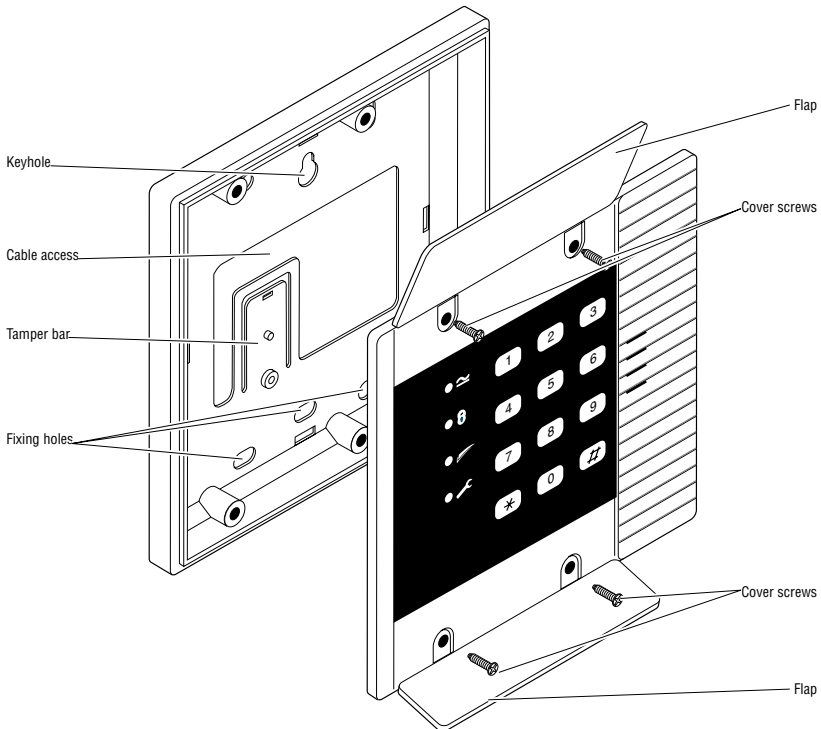

Figure 8. 9925 Backplate

Wiring the Control Unit

Cable Entries

The control unit case back provides several cable entries. The back is designed to stand away from the wall to leave space for cables.

Mains Connection

The control unit must be permanently connected to a spur outlet fitted with a readily accessible disconnect device. Connect the mains supply to the control unit using the 3-way terminal block located in the control unit back. Secure the mains cable to the case anchor point using the cable tie provided. Note that the control unit has a T-250mA internal mains fuse. All electrical connections should be carried out by a qualified electrician and must comply with the current IEEE Wiring Regulations: 16 Edition, Appendix 5 - Standard Circuit Arrangement.

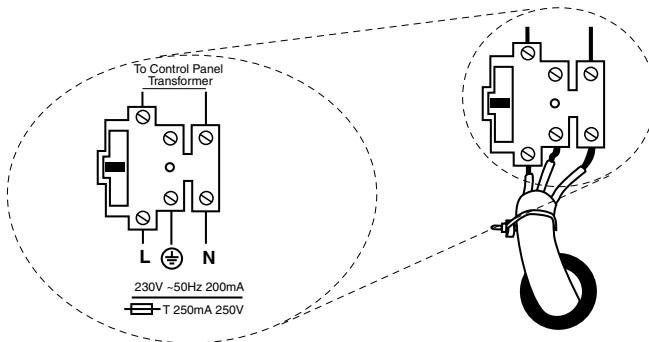

Figure 9. Mains Connection

Connect the 21VAC lead from the mains transformer to the main pcb.

Caution: Do not apply mains power at this point. Do not work inside the control unit case when mains power is present.

Remote Keypads

Keypad Addressing

The 9750 control unit is supplied with one remote keypad. If you have fitted more keypads then each one must be given a separate "address". Links LK2 to LK4 set the keypad address, as shown in Figure 10.

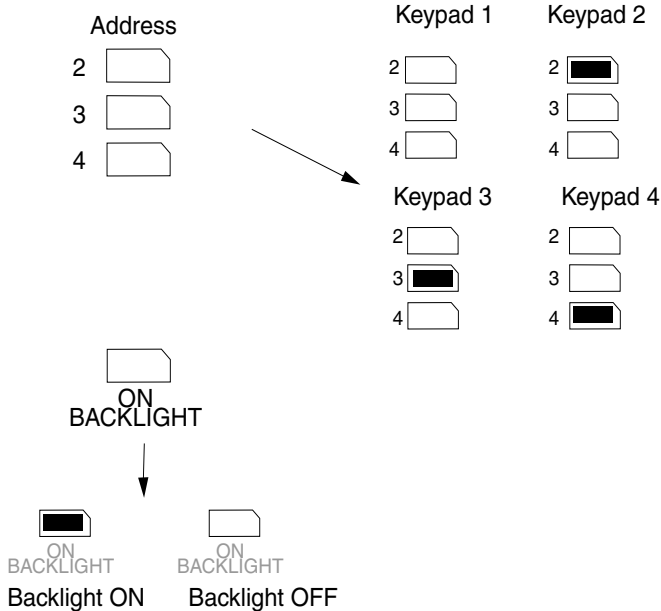

Figure 10. Keypad Addressing.

Keypad Backlight

When supplied from the factory the control unit is configured with the keypad backlight ON. To turn the keypad backlight OFF remove the jumper from the "ON BACKLIGHT" link, shown in Figure 10.

Connecting Keypads

Figure 11 shows the connections for any of the remote keypads.

Exit Terminate Button

To connect an exit terminate button use the "ET" connector terminals on the keypad PCB. See Figure 11.

Sounders

Figure 11 shows the connections for the internal and external sounders.

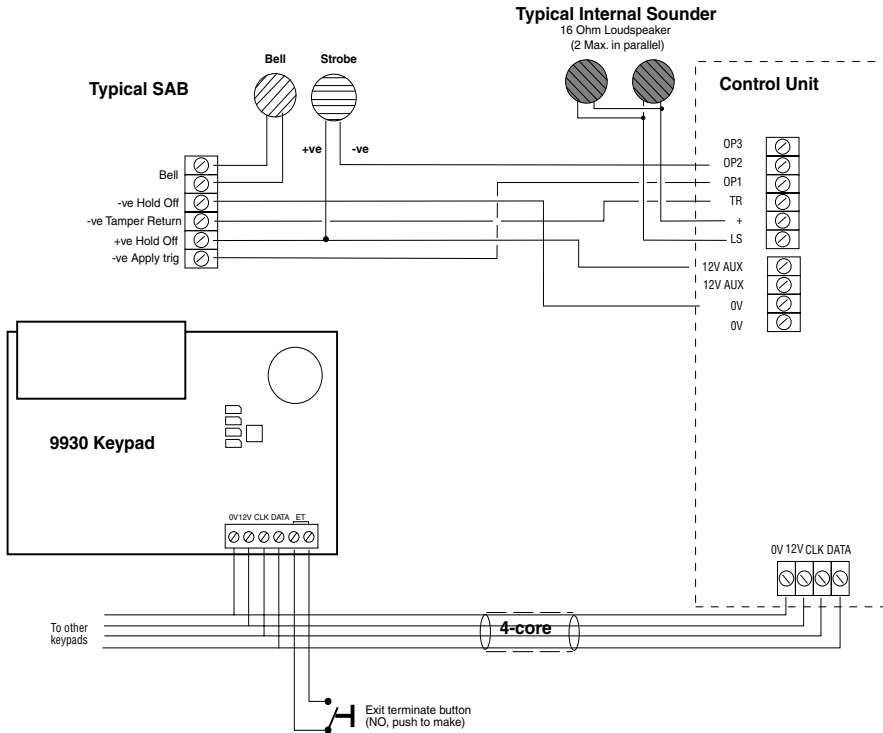

Figure 11. 9750 Keypad and Sounder Connections

Detector Circuit Connections

The left hand edge of the main PCB provides 14 connectors that can be used for up to 8 zones.

Four Wire CC Connections

Figure 12 shows how to connect four wire CC zones. Note that pairs of alarm contacts share contacts. You should wire the tamper contacts of all detectors in series and then connect them to the contacts marked "A/T". The control panel provides enough connectors for eight four wire circuits. If you wish to connect 16 four wire circuits you must fit a 9755 hardwired expander card (see "Connecting a 9755 Expander").

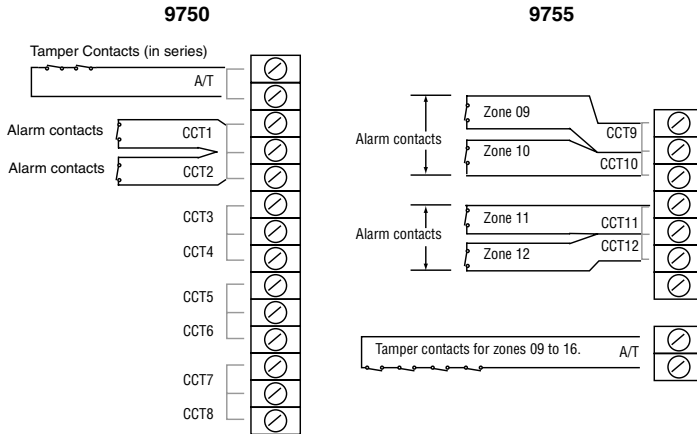

Figure 12. Four Wire Closed Circuit Connections

Connecting a 9755 Expander

Figure 13. shows how to wire a 9755 Expander to the control unit.

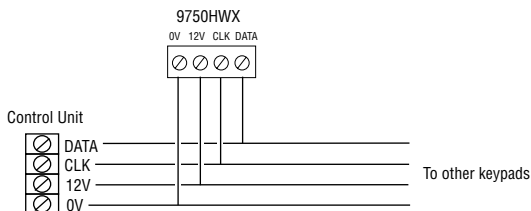

Figure 13. Connecting a 9755 Expander

Once you have connected an expander refer to the instruction supplied in order to connect detectors.

Using Programmable Outputs

OP1, 2 and 3 are "pull down type" outputs that provide negative applied control signals. The system adjusts the output polarity when you select the output type. Use programming command 81 for OP1, command 82 for OP2 and command 83 for OP3 (see "4. Programming"). Figure 14 shows some example applications for OP3.

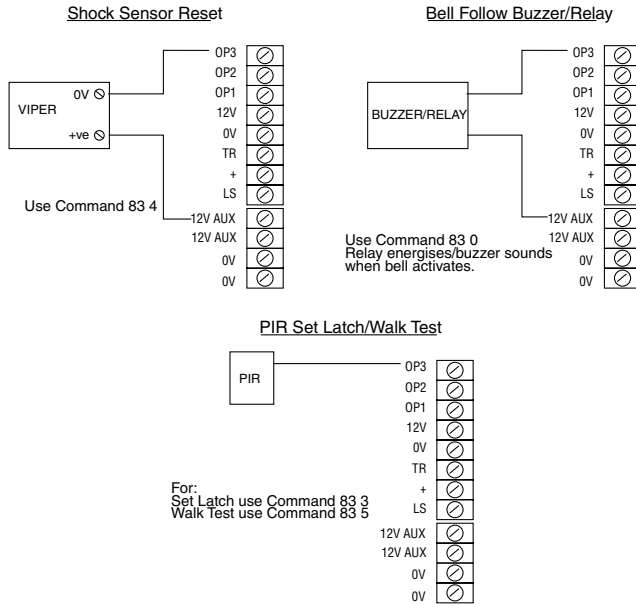

Figure 14. Wiring Examples for Programmable Output OP3

Wiring Keyswitches

Figure 15 shows the connections for a 9928 Keyswitch Interface.

Note: You can fit only one keyswitch interface per system.

Momentary or Continuous Keyswitches

The 9928 keyswitch interface can be connected to either momentary or continuous keyswitches, see Figure 15. When using a momentary keyswitch remove the jumper from link M/C. When using continuous keyswitches fit a jumper to link M/C.

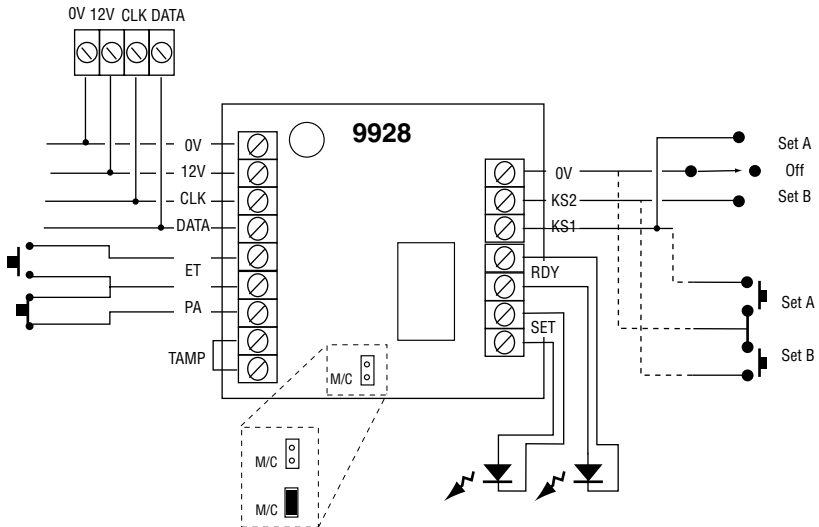

Figure 15. Connecting a Keyswitch Interface

Installing a Communicator

The 9750 control unit contains a built in communicator on the main PCB. In addition the control unit can be connected to a separate communication device using a wiring harness connecting to interface pins on the main PCB.

Built in Communicator

The built in communicator is a 300 Baud Auto Dialling Modem. The communicator can be used for:

- Transmitting alarm signals to alarm receiving equipment at a central monitoring station using either Scancom Fast Format, Scancom SIA (Security Industry Association), or Contact ID.
- Connecting to a PC based at a remote engineering centre. By using Scantronic <Downloader> software, the remote PC can up- or download system parameters (including the event log and diagnostics), set and unset the alarm system, and carry out other special functions.

Telephone Line

The built in communicator can be connected directly to an ex-directory line used exclusively for alarm communications.

Where an exclusive line is not available and other apparatus is connected to the line, for example an answer machine, the built in communicator provides a series connection with line divert for the other apparatus. When triggered, the communicator seizes the line and disconnects the other apparatus while the communicator is operational. When the communicator has shut down, it reconnects the other apparatus.

Note: Ideally, no other equipment should be connected to an exclusive line.

Three Way Calling

The 9750 also provides a Three Way Calling facility to make sure the built in communicator can always use a shared telephone line.

To use this facility, the local exchange must provide the Three Way Calling service on the customer's line.

Line Monitoring

The 9750 provides functions programmed by commands 106 and 107 to ensure that the telephone line is connected and working, and to indicate a line failure:

- While communication is enabled **Line Monitor** continually checks the line voltage to ensure that the line is connected.
- **Line Integrity** (programming command 107) checks the line to make sure the local exchange is still responding.

If either of these functions detect a failure the system gives a programmable Line Fault Response (programming command 106).

Statutory Information

Application

The built in communicator is suitable for connection to the following type of networks:

- (a) Direct exchange lines (PSTN) supporting DTMF (tone) dialling.
- (b) PABX exchanges (with or without secondary proceed indication).

Note: The built in communicator is not suitable for connection as an extension to a pay-phone or to 1 + 1 carrier systems.

Compatible PABXs

The built in communicator is only approved for use with compatible PABXs. Correct operation in all circumstances is not guaranteed.

Approval

This product is manufactured to meet all European Economic Area telecommunication networks requirements.

The equipment has been approved in accordance with Council Decision 98/482/EC for pan-European single terminal connection to the public switched telephone network (PSTN). However due to differences between the individual PSTNs provided in different countries, the approval does not, of itself, give an unconditional assurance of successful operation on every PSTN network termination point.

In the event of problems you should contact you equipment supplier in the first instance.

The built in communicator has been approved for the following usage:

- (a) Automatic call initialisation.
- (b) Operation in absence of proceed indication.
- (c) Automatic Dialling.
- (d) Modem.
- (e) Serial Connection.
- (f) Multiple Repeat Attempts.
- (g) Line Status Monitoring.

Usage other than approved usage or failure to comply with the installation and programming instructions may invalidate any approval given to the apparatus, if, as a result, the apparatus ceases to comply with the standards

3. Installation

against which approval was granted. Note the approval label on the main PCB.

REN

The Ringer Equivalence Number (REN) of the built in communicator is 1. As a guide to the number of items of apparatus which can be simultaneously connected to an exclusive line, the sum of the REN values should not exceed 4. A BT provided telephone is assumed to have a REN value of 1.

Safety Notice

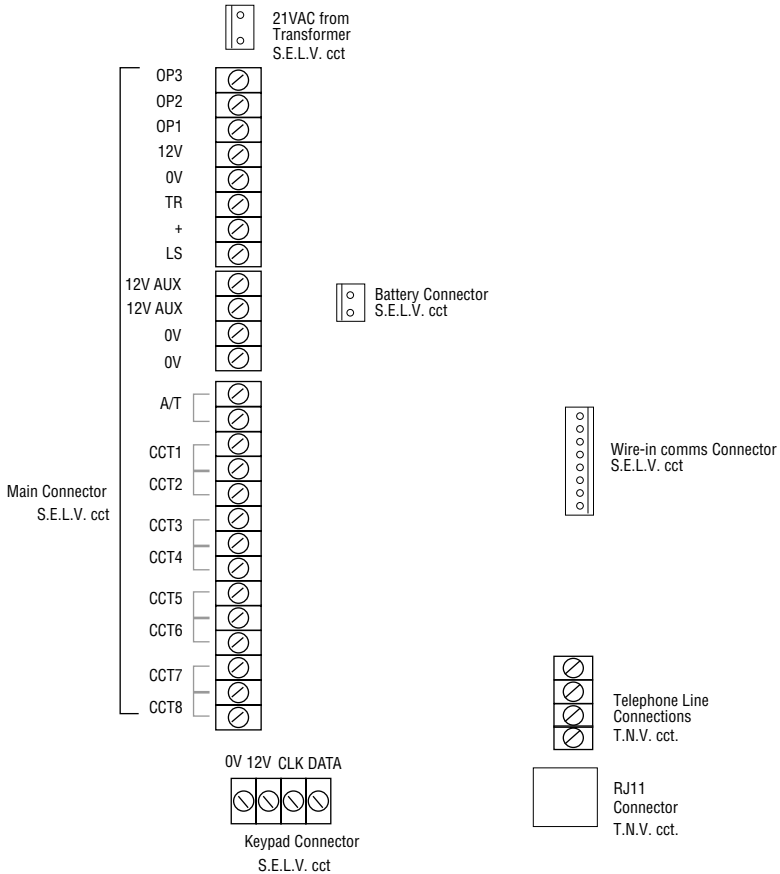

Figure 16. SELV and TNV Connectors on the 9750

The terminals on the 9750 control unit main pcb are described as Safety Extra-Low Voltage circuits (SELV), according to the definitions in Safety Standard EN60 950.

The terminals on the built in communicator are described as SELV or Telecommunications Network Voltage (TNV) according to the definitions in Safety Standard EN60 950.

Note: The SELV and TNV connections which are shown in Figure 16 are for reference only and do not appear on the 9750 main pcb.

It is important that the installer ensures that TNV terminals are connected ONLY to the PSTN or other circuits designated as TNV circuits. SELV terminals must be connected ONLY to other circuits designated as SELV circuits. Strict adherence to the installation instructions will ensure that the equipment continues to comply with safety regulations to which it was approved.

Connecting the Telephone Line

Direct connection, or interconnection via other apparatus, to the terminals on the built in communicator can produce hazardous conditions on the telephone network. Always seek advice from a competent telephone engineer if in any doubt regarding connection to these terminals.

The person responsible for connection of the built in communicator to a PABX system must be as follows:

- a) If the wiring is owned by British Telecom PLC, British Telecom must connect the wiring to the communicator.
- b) If the wiring is not owned by British Telecom, either:
 - (i) British Telecom
 - (ii) The authorised maintainer
 - (iii) A professional installer after 14 days written notice to the authorised maintainer.

Connect the telephone line as follows (see Figure 17):

1. Using a three core cable (type 1/05mm CW1308), strip back 5mm of two cores and feed through one of the cable entries in the rear of the 9750 casing. Connect the two cores to the terminals, A and B on the built communicator.
2. Connect the cable from the A and B terminals on the built in communicator to the corresponding terminals on the BT master box.
3. If other apparatus is required to share the telephone line with the built in communicator (series apparatus), connect the main apparatus to the series switched line connections marked A1, B1.

Caution: The connection of only one such series apparatus is allowed to be connected between a main apparatus (e.g., telephone) and the PSTN.

Take care to ensure that the A and B line are connected correctly (i.e. correct polarity). The built in communicator continuously monitors the line for Ringing tones.

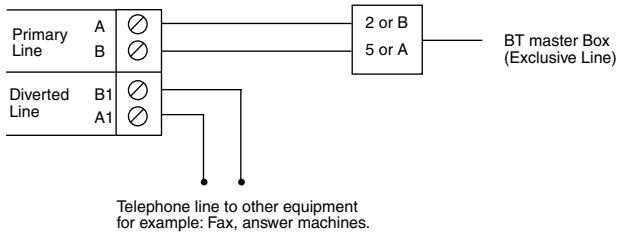

Figure 17. Connecting the Built In Communicator

Fitting a Plug-by Communicator

The 9750 can be fitted with a communicator or speech dialler (for example the Scantronic 8400, 8440, 660 or RedCare STU). To fit a communicator, follow the instructions below.

Caution: Follow the instructions in the order shown, or you may damage the control unit and/or communicator.

1. Disconnect mains and battery power from the control unit and remove the case lid, if the system has already been installed.
2. Detach the main PCB from the support pillars in the control unit case, and lift the PCB carefully to the left.
3. Fit the communicator between the PCB support pillars, making sure that the main PCB can fit back into position (see Figure 18).

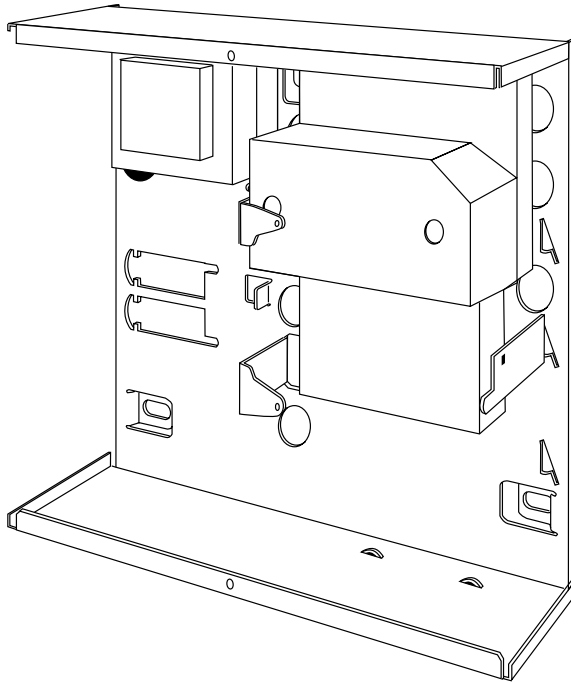

Figure 18. Fitting a Plug ByCommunicator

4. Make any necessary connections from the communicator to the Comms Wiring Harness. Figure 19 shows the outputs available on the free ends of the Comms Wiring Harness.

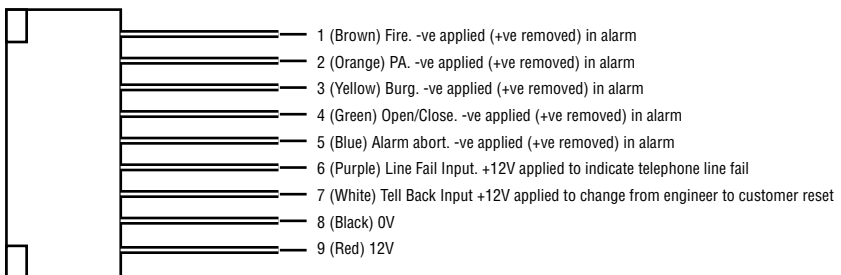

Figure 19. Communications Wiring Harness.

5. Plug the Comms Wiring Harness onto the communications connector on the main PCB (see Figure 4).
6. Re-fit the PCB to the support pillars.

3. Installation

If the system has already been installed:

7. Re-connect the battery.
8. Fit the case lid (don't forget to attach the earth lead from the case to the left hand support pillar).
9. Apply mains power.
10. Test communicator operation.

Fitting a Battery

Fit a rechargeable battery into the back of the case. The case provides space for a 12V 7AH battery. Make sure the battery terminals are oriented in the position shown in Figure 20.

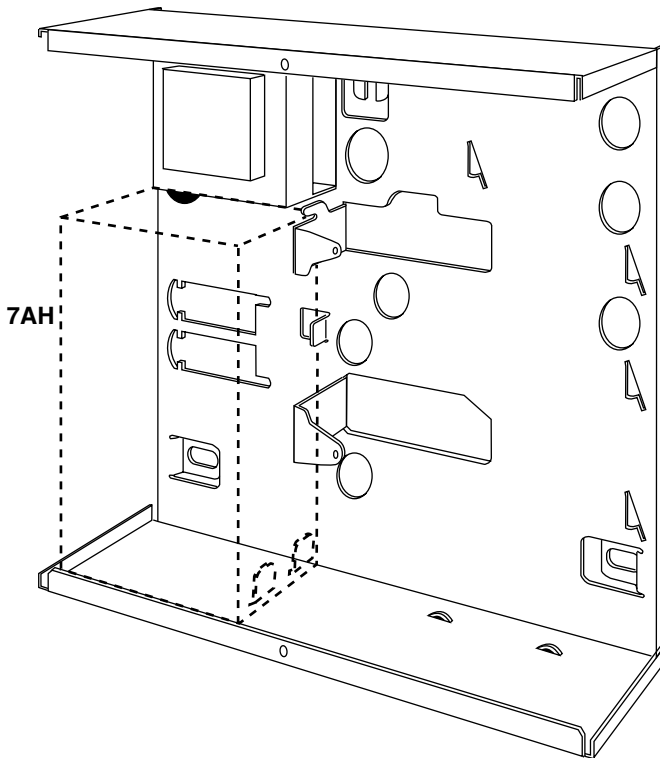

Figure 20. Fitting a Battery

Initial Start Up

Before applying power to the control unit, ensure that any remote keypad(s) have been addressed, and expanders, zone circuits and sounders are connected.

1. Connect the battery to the control unit PCB.
The green power LED flashes and the internal sounder may sound.
Ignore any other display at this stage.
2. Key-in the factory default user access code: 1234.
The internal sounder stops. Ignore any other display at this stage.
3. Please fit the case lid before applying mains power (this also defeats the tamper switch).
4. Apply mains power.
The Power LED glows steadily.
5. Key-in 0 followed by the factory default engineer access code: 7890.
(You do not have to remove the control unit lid.)

The display shows:

Installer Mode

You are now in programming mode.

3. Installation

4. Programming

Entering Programming Mode

“3. Installation - Initial Power Up” describes how to enter programming mode for the first time in a new installation. If you wish to enter programming mode at any other time:

1. Make sure the system is unset.
2. Press 0, then key in the Engineer’s code (default 7890).

The display shows:

Installer Mode

You are now in programming mode.

Note: While the system is in programming mode all keypads except the one you are using will be locked, displaying “Busy”.

Programming Commands

When delivered from the factory the control unit already has default program settings. To change the default programming you must be in programming mode. Then:

1. Key in the appropriate command number and press ✓.
The display shows the current value of the command.
2. Key in digits to select the value you require.
The display shows the new value.
3. Press ✓ to store the new value of the command.

If at any time you change your mind, repeat step 1 to 3. The table on the following pages shows the commands and their options. (A “Y” next to a command value shows that it is the factory default.)

The factory default access codes are:

Engineer Code	7890
Access Code User 1	1234
Access Code 2 to 8	X 002 X 008 (inactive)
Duress Code	X009 (inactive)

Notes:

1. *The factory default Access Codes 02 to 08 and the Duress Code must be changed by USER 1 to a four digit number to activate them. See “9750 User Guide” for a more detailed explanation of changing user access codes.*
2. *To change the default zone descriptions use <Downloader>.*

4. Programming

To change:	Key-in:	Notes	Default
Zone nn (Note: for zones 1 to 9 key in "01" to "09".)	nn✓✓ab	nn = zone number 01 to 16 <u>a = Zone type, one of:</u> 0 = NU (not used) 1 = PA (panic alarm) 2 = FR (fire zone) 3 = NA (normal alarm) 4 = 24 (24 hour zone) 5 = FE (final exit) 6 = ER (entry route) 7 = SA (Shock Analyser) 8 = TC (Technical) <u>b = Zone attributes, any of:</u> ✗1 = C (chime) ✗2 = S (soak test) ✗3 = D (double knock) ✗4 = O(Omit allowed) ✗5 = b (armed in part set B) ✗7 = Shock Analyser sensitivity (enter a number in the range 1 (lowest) to 4 (maximum))	Z01 =FEb Z02=ERb Z03-Z07=NAb Z8=PA Z09-Z16=NU
Example: Zone 3 is a Normal Alarm, active in Part Set B, that is Omit Allowed. Type in:	03✓✓	Zone Number 3 Normal Alarm ✗5 Active in Part Set B ✗4 Omit Allow ✓ to store the value of the command.	
Engineer Code	20✓nnnn	nnnn = New engineer code	7890
LS Chime Output	22✓ n	Loudspeaker chime volume 0 = Off (Keypad only) 1=low, 9=max	5
RedCare reset	23✓ 0	Off 1 On	Y
Internal Sounder	25✓ 0	LS Timed (Follows external bell) 1 Continuous	Y
Sounder Delay on Entry	26✓ 0	Bell Delay off 1 Bell Delay on	Y
Exit fault external sounder	27✓ 0	Internal 1 Local	Y
Status display	28✓ 0	Status off (180 seconds after setting) 1 Status on	Y
PA Response	30✓ 0	Audible 1 Silent	Y

To change:	Key-in:	Notes	Default
System Reset	33✓ 0	Eng reset off 1 Eng reset on	Y
PA Reset	34✓ 0	PA cust reset 1 PA eng reset	Y
First circuit lockout	35✓ 0	Lock out on 1 Re-arm	Y
Alarm Abort	36✓ 0	Abort off 1 Abort on	Y
Day tamper comms	37✓ 0	Day Tamper off 1 Day Tamper on	Y
Level A Exit Mode	39✓ 0	Timed 1 Terminated 2 Final door set	Y
System Auto Re-Arm	40✓ 0	Rearm Never 1 Rearm 1 2 Rearm 2 3 Rearm 3 4 Rearm Always	Y
Bell Delay	41✓ 0	No delay 1 1.5 minutes 2 3 minutes 3 5 minutes 4 10 minutes 5 15 minutes 6 20 minutes	Y
Bell Duration	42✓ 1	1.5 minutes 3 minutes 5 minutes 10 minutes 15 minutes 6 20 minutes	Y
Level A Entry Time	43✓ 1	1 10 Seconds 2 20 seconds 3 30 seconds 4 45 seconds 5 60 seconds 6 120 seconds	Y

4. Programming

To change:	Key-in:	Notes	Default
Level A Exit Time	44✓	1 10 Seconds	
		2 20 seconds	Y
		3 30 seconds	
		4 45 seconds	
		5 60 seconds	
		6 120 seconds	
Entry/Exit Volume	45✓ 0	No Entry/Exit tones from Loudspeaker	
		n EE tone volume from LS (1=low, 9=max)	5
CSID Code	50✓	n....n Seed code for remote reset	none
Set Time and Date	51✓ see "Setting Time and Date"	
Abort reset	53✓ 0	Abort System	Y
		1 Abort User	
Level B final exit operation	60✓ 0	B=FE = FE (Final exit)	Y
		1 B=FE = NA (Normal alarm)	
Level B Entry route	61✓ 0	B=ER = ER (Entry route)	Y
		1 B=ER = FE (Start entry timer)	
Level B Exit Mode	62✓ 0	Low Tone	Y
		1 Instant set	
		2 Silent set	
Level B Alarm response	63✓	0 Keypad Sounder Only	
		1 Internal Sounder and keypad sounders	Y
		2 Local (all sounders, no comms)	
		3 Full alarm (all sounders and comms)	
Level B Entry Time	64✓	1 10 seconds	
		2 20 seconds	Y
		3 30 seconds	
		4 45 seconds	
		5 60 seconds	
		6 120 seconds	
Level B Exit Time	65✓	1 10 Seconds	
		2 20 seconds	Y
		3 30 seconds	
		4 45 seconds	
		5 60 seconds	
		6 120 seconds	

To change:	Key-in:	Notes	Default
Output 1 Type, one of	81 ✓	0 Bell 1 EE follow 2 Armed lamp 3 Set latch 4 Shock sensor reset 5 Walk test 6 Ready lamp 7 24 hour alarm 8 Strobe 9 Smoke sensor reset	Y
Output 2 Type, one of	82 ✓	0 Bell 1 EE follow 2 Armed lamp 3 Set latch 4 Shock sensor reset 5 Walk test 6 Ready lamp 7 24 hour alarm 8 Strobe 9 Smoke sensor reset	Y
Output 3 Type, one of	83 ✓	0 Bell 1 EE follow 2 Armed lamp 3 Set latch 4 Shock sensor reset 5 Walk test 6 Ready lamp 7 24 hour alarm 8 Strobe 9 Smoke sensor reset	Y
Dual ply entry	86 ✓	0 Off 1 On (not recommended in U.K.)	Y
Dual key PA (Incl. keyswitch)	87 ✓	0 Off 1 On	Y
Alarm confirmation	89 ✓	0 Confirm off 1 Confirm on	Y
Event log*	90 ✓	1 View earlier events 3 View later events ✗ Cancel viewing ✓ Toggles time/date display	
Engineer Walk Test*	97 ✓	Zn indication and chime operate when cct open ✓ (Clear)	End walk test

* See "5. Testing"

To change:	Key-in:	Notes	Default
Load defaults	98✓1✓	Load defaults	
Leave programming	99✓		

Communications Programming

Call mode	101✓0	Disabled	Y
		1 Single	
		2 Alternate	
		3 Dual	
Reporting type	103✓0	Fast format	Y
		1 Contact ID	
		2 SIA I	
		3 SIA II	
Line fail response	106✓0	Disabled	
		1 Audible	Y
		2 Silent	
Line integrity checking	107✓0	Integrity off	Y
		1 Integrity on	
Dynamic testing	108✓0	Dynamic off	Y
		1 Dynamic on	
Three way calling (UK)	109✓0	Three way off	Y
		1 Three way on	
Download Mode	110✓1✓	Remote	Y
		(No other option available on 9750)	
Rings to answer	112✓0	3 rings	
Downloading option		1 5 rings	Y
		2 7 rings	
		3 10 rings	
		4 15 rings	
Answer on one ring	113✓0	One ring off	Y
Downloading option		1 One ring on	
Access Mode	114✓0	Callback off (Attended)	Y
		1 Callback on	
		2 Callback any (Unattended)	
Communicator Tel No 1	115✓✓	Maximum 31 digits	
Communicator Tel No 2	116✓✓	Maximum 31 digits	
Account No 1	117✓✓	Maximum 6 digits	

To change:	Key-in:	Notes	Default
Downloader Tel No 1	118 ✓✓	Maximum 31 digits	
Downloader Tel No 2	119 ✓✓	Maximum 31 digits	
Fast Format channels	121 ✓ a ✓b ✓		
For built in Communicator		a is the channel number 1 to 8 b is one of the following:	
		0 Not Used	
		1 Fire	Y
		2 PA	Y
		3 Burglar	Y
		4 Open/Close	Y
		5 Alarm Abort	
		6 Technical Alarm	
		7 Alarm Confirmation	
		8 RF Detector Low Battery	
		9 RF Supervision Loss	
		X1 Jamming	
		X2 AC Fail	
		X3 Tamper Alarm	
		X4 Open	
		X5 Close	
		X6 Zone Omitted	
Restoral reporting	123 ✓ 0	Restore off	Y
	1	Restore on	
Country	126 ✓nn		
<u>nn = country, one of:</u>			
0 = UK (Y)	5 = Italy	10 = Ireland	
1 = NL	6 = Spain	11 = OEM 1	
2 = Belg. (Flemish)	7 = Denmark	12 = OEM 2	
3 = Belg. (French)	8 = Norway		
4 = France	9 = Sweden/Finland		
Note: If you carry out this command then the system will load all defaults for the selected country.			
Extended Report mode	131 ✓ 0	Basic	Y
	1	Summary	
	2	Intermediate	
	3	Full	
SIA Tones	132 ✓ 0	Bell 103	Y
	1	CCITT V21	
CID Report Restorals	143 ✓ 0	Mode Basic	Y
	1	Mode Basic + Restore	

Leaving Programming Mode

When all programming has been completed:

1. Key-in '99 ✓' at the keypad

The display shows:

99:Exit Eng ?

2. Press ✓.

The display shows:

99:Checking Sys

followed by the time and date.

The system is now in user mode.

Note: If there is a fault on the system , for example an open tamper circuit, the display shows this and will not return to Day mode. Press ✓ (Clear) and rectify the faults.

Engineer Reset

To perform an Engineer Reset:

1. Check that the display is showing the alarm condition.
2. Key in 0 followed by the Engineer's code (default 7890), followed by 99 ✓✓.

The display shows the time and date.

Re-entering Programming Mode

You can go back into programming mode whenever the system is unset and not in alarm:

1. Key in 0 followed by the Engineer's code (default 7890).

The display shows:

Installer Mode

You are now in programming mode.

Restoring the Access Codes (1st stage reset)

If the user and/or engineer codes are lost, then:

1. First remove mains power and then open the case and disconnect the battery.
2. Identify the NVM Reset pins on the main pcb (see Figure 4).
3. Short the Reset pins together using a small wire link.
4. Reconnect the battery.
5. Remove the short from the Reset pins.

The control unit loads the factory default access codes:

User 1: 1234.

Engineer: 7890.

6. Close the control unit and apply mains power.
7. Carry out an engineer reset.

Restoring All Factory Default Programming

If you wish to restore all factory default options then:

1. Enter programming mode (if you are not already there).
2. Key in 98 ✓ at the keypad.

The display shows:

98:Load Default

3. Press 1. (You can press X to stop the procedure if you change your mind at this stage.)
4. Press ✓.

The keypad gives a double confirmation tone and the system loads the factory default command values, erasing all previously programmed values.

Notes: The log is protected and cannot be erased by the Installer.

Programming Reference

Zone Programming (Commands 01 to 16)

The zone programming commands 01 to 16 take two or more numbers. The first number describes the zone type, subsequent numbers describe the zone attributes.

When you key in the zone number and press ✓ the display shows the zone number and any text caption for the zone. (Note that the zone text can be changed using <Downloader>, but not from the keypad.) Press ✓ again to start entering the zone types and attributes. When you have entered the zone type and attributes press ✓ once more to store the changes.

Zone Types

The following types are available:

Not Used (NU) The system ignores Zones with this type. Key in 0 for zone that will not be used.

Note: If a zone is programmed as 'Not Used', it is not necessary to link the circuit or anti-tamper connections.

Panic Alarm (PA) (Key in 1) Operating a device programmed as 'Panic Alarm' will start either a silent alarm transmission to the central station, or an audible alarm, depending on how you have programmed PA Response, (see command 30). PA alarms operate whether the system is set or unset, and cannot be omitted.

Fire (FR) (Key in 2) Smoke or heat detectors connected to FR type zones cause the speakers to give a distinctive fire signal (internal sounders pulsing "Dee Dah Dee Dah..."). Fire

alarms operate whether the system is set or unset and cannot be omitted, and will always trigger communications if fitted.

Normal Alarm (NA) (Key in 3) A zone programmed as 'Normal Alarm' will start an alarm when the system is set.

24 Hr Zone (24) (Key in 4) This zone causes an internal alarm if violated when the system is unset, and a full alarm if the system is set. Providing the Installer programs 24hr zones with 'Omit Allow', the user can omit 24 hour zones in Day mode. Note that the control unit re-instates all 24Hr zones if anyone sets the system.

Final Exit (FE) (Key in 5) Zones of this type must be the last detector to be activated on exit, or the first to be activated on entry. You can use zones of this type to finally set the system, or to start the entry procedure. Use command 39 to set the exit mode type.

Entry Route (ER) (Key in 6) Use this zone type for detectors sited between the Final Exit door/detector and a keypad. If an 'Entry Route' zone is violated when the system is set, an alarm will occur. If the entry/exit timer is running when an Entry Route zone is violated then no alarm occurs until the entry/exit timer expires.

Shock

Analyser (SA) (Key in 7) You can apply this zone type to zones 1 to 4. The system will not accept the attribute for zones 5 to 16. (See also "Zone Attributes - Sensitivity".)

Technical (TC) (Key in 8). Use this zone type when you want to monitor equipment, for example a freezer, without raising a full alarm.

If a technical alarm zone is activated while the system is set, the system makes no audible alarm. However, when a user unsets the system the keypad indicates a fault.

If a technical alarm zone is activated while the system is unset then the system starts a pulsed tone from the keypad. If programmed, the control unit also starts communication. When a user enters a valid code the keypad stops the tone and displays the zone.

Zone Attributes

Specific zone types can have one or more attributes programmed by the digit after the zone command and type. (To remove an attribute, key in the attribute digit again.)

Chime (C) (Key in **✕1**) When enabled by the user, the system gives a non-alarm warning tone when any zones programmed as 'Chime' are opened. This facility operates only while the system is in Day.

Notes:

1. 'Chime' is available only for Normal Alarm, Final Exit, Entry Route and Shock Analyser zone types.
2. To make chime available from the keypad sounders but not the internal sounder then program command 22 with option 0.

Soak Test (S) (Key in **✕2**) Use this zone attribute if you want to place under long term test a detector that you suspect is giving false alarms. Zones with this attribute are disabled. If the zone is opened while the system is set then the Service LED glows and the control unit logs the event as a "Soak Test Fail Zn" (n is the zone number) without sounding any bells or starting signalling. The Service LED stays alight until the Engineer resets the system.

Note: Soak test is available only for Normal Alarm, Entry Route and Shock Analyser zone types.

Double

Knock (2) (Key in **✕3**) Zones with this attribute will cause an alarm condition only if the sensor generates two alarms events within a five minute time window, or if the zone remains open for more than 10 seconds. Programming a zone as 'Double Knock' is a way of reducing false alarms caused by environmental changes, but is not normally recommended.

Note: 'Double Knock' is available only for Normal Alarm and Entry Route zone types.

Omit Allow (O) (Key in **✕4**) When applied to a zone, this attribute allows the user to omit the zone.

*Note: 'Omit Allow' is **not** available for Final Exit, PA and Fire zones.*

Part Set B (b) (Key in **✕5**) When applied, the zone will be armed when the user selects Part Set B. Zones not selected will be omitted.

Sensitivity (Key in **✕7**) When you use this command you must also enter an extra digit in the range 1 to 4 in order to set the sensitivity of the shock sensor. 1 is least sensitive, 4 is most sensitive. Note that to use this attribute you must make one of zones 1 to 4 a shock analyser type. To

adjust the sensitivity you must enter the complete command, for example to change the sensitivity to 3 you must key in: **X7 + 3**.

Change Engineer Code (Command 20)

To change the Engineer access code:

1. Make sure you are in programming mode.
2. Key in 20 and press ✓.

The display shows:

20: Code

3. Key in a new four digit Engineer access code.

The display shows:

20: Code ****

4. Press ✓.

Loudspeaker Chime (Command 22)

A user may find that the chime tone from the keypads is not loud enough. If so, then use command 22 option 1 to make the internal sounder also give the chime tone. To alter the volume of the tone from the internal sounder enter a digit in the range 1 to 9. 1 is quietest, 9 is loudest. The keypad demonstrates the volume of the tone when you enter the digit.

RedCare Reset (Command 23)

Option 1 enables RedCare Reset, which is designed to operate with the plug-by communicator, or remote PC reset.

Note: You must set System Reset to Engineer (Command 33 option 1) to ensure RedCare Reset works correctly.

After an alarm the user keys in their access code to silence the alarm, but cannot reset the system. The first to alarm and Service LEDs remain lit. The user contacts the central station, who verify the user's identity. The central station can send a signal back to the control unit. The Service LED goes dark and the the end user can now reset the system with any valid access code, providing that there are no faults.

Use option 0 (the default) to disable the function.

Continuous Sounder (Command 25)

Option 0 of this command makes the internal sounder follow the external bell delay and duration times. Option 1 makes the internal sounder continue after the external bell times out.

Local Sounder Delay on Entry (Command 26)

Use option 1 (default) to delay local sounders for silent communications when an entry alarm is triggered (required by some police forces). This option is only valid if you have programmed a Bell Delay.

Use option 0 for no delay.

Exit Fault External Sounders (Command 27)

When programmed with option 0 of this command the system operates the internal sounders if the user tries to exit while a zone is still violated (for example a door is not shut). When option 1 is programmed the system operates the external sounders as well as the internal sounders.

Status Display (Command 28)

Use option 0 of this command if you do not wish to show keypad displays permanently. The keypad displays “Level Set” for 180 seconds after the user sets the system and then reverts back to the time and date display. Use this option when installing a system in the U.K.

When set to option 1 the keypad displays “Level Set” the whole time that the alarm system is set.

Silent or Audible PA (Command 30)

This command selects how the system responds when a PA zone operates.

Option 0 (audible PA): the system operates the sounders and, if a communicator is fitted, sends a PA message to the central station. The keypad displays the PA zone when a user disarms the system.

Option 1 (Silent PA): The sounders stay silent. If a communicator is fitted the system sends a PA message to the central station. The keypad displays the PA zone when a user disarms the system.

System Reset (Command 33)

If you wish to make the system engineer reset, then use option 1. For user reset use option 0.

Certain types of event will always need an Engineer reset, no matter what option you choose for command 33. These events are:

Activating the tamper switch on the control unit, keypads, or expanders.

Auxilliary 12V supply fuse blown.

Remote expander failure caused by a remote keypad not responding correctly.

Tamper return violation (usually from the external bell).

A low battery at the control unit.

Soak test fail indication.

PA Reset (Command 34)

If you wish to make the system engineer reset after a PA alarm then use option 1. For user reset use option 0.

First Circuit Response (Command 35)

If you select option 0 (Lock out) then the complete system rearms at the end of the programmed bell run time, but excludes the first zone to activate during the set cycle.

If you select option 1 (Re-arm) then, when an alarm occurs, the complete system (including the first zone to activate) rearms at the end of the programmed bell run time (providing the zone is closed). While the zone is open, the system locks it out. If the zone closes after the system rearms, the system reinstates it.

Alarm Abort (Command 36)

Users occasionally trigger false alarms by accident. The 9750 can be programmed to allow users to abort an alarm by enabling option 1.

If a user accidentally triggers an alarm while the system is set, then the control unit activates Channel 3, starts the bell delay timer and alarm abort timer. To abort the alarm the user must enter a valid access code during the abort period. When the user successfully enters the code during the abort period the system deactivates Channel 3 and triggers the programmed abort channel simultaneously in order to signal a separate code abort, as required by some alarm receiving centres.

Note: The alarm abort period is controlled by the alarm receiving centre.

Daytime Tamper Communication (Command 37)

This command controls how the control unit reports tampers while the alarm system is unset.

With option 1 selected the system communicates these types of tamper event to the central station and starts the internal sounder.

With option 0 selected the system starts the internal sounder only.

Level A Exit Mode (Command 39)

Use this command to select one of the system's three exit modes:

Option 0: Timed. Use this option EITHER if the user completes setting the system by pushing an exit terminate button connected to a keypad OR if no exit terminate button is connected, and the system sets after a delay selected using Command 44.

Option 1: Terminate. Use this option if the user completes setting the

system by pushing an exit terminate button connected to a keypad. Note that the exit time is infinite in this option.

Option 2: Final door set. Use this option to complete setting the system by closing a door fitted with a Final Exit zone detector. Note that the exit time is infinite in this option.

If a PIR detector covers the final exit door then selecting Final Door Set is not recommended: exit faults may occur if the detector responds to transient drafts caused by the door closing.

System Auto Re-Arm (Command 40)

This command lets you program the number of times that the system will re-arm when the bell delay expires. The system re-arms all closed zones. Select option 0 to make the system never re-arm (the system will go into alarm once only). Select options 1 to 4 to make the system re-arm once, twice, three times or always.

Use this command in conjunction with command 35 - First Circuit Response.

Bell Delay (Command 41)

When the system is set and (for example) an intruder violates a zone, then the system waits for the programmed Bell Delay before operating the external sounder. The system then operates the external sounder for the programmed Bell Duration. See “Programming Commands” for the command options.

Bell Duration (Command 42)

This command lets you set the length of time the system will operate the external sounder during an alarm. See “Programming Commands” for the command options.

Level A Entry Time (Command 43)

This command lets you set the Entry Time for Level A (full set). See “Programming Commands” for the command options. The time starts when a user opens any Final Exit zone.

Level A Exit Time (Command 44)

This command lets you set the Exit Time for Level A (full set). See “Programming Commands” for the command options.

Entry/Exit Tone Volume (Command 45)

Use this command to set the volume of entry/exit tones from the internal sounder. If you select option 0 then the internal sounder gives no entry/exit tones. If you select option 1 then the internal sounder gives quiet entry/exit tones, while option 9 gives the loudest entry/exit tones. The keypad demon-

strates the volume of the tone when you enter the digit.

CSID Code (Command 50)

To allow the customer to use the 'Remote Reset' facility, you must program the control unit as 'Engineer Reset' (Command 33 option 1) and then install a four digit Central Station Identification (CSID) code.

First make contact with the central station and obtain the CSID code, then ensure that the system is in programming mode. Key in:

50 ✓ nnnn ✓

Where nnnn is the "CSID Code".

The control unit now contains the same CSID code as the central station. After an alarm the control unit can generate a 'Control Code' which will be recognised by the central station 7300 Remote Reset decode programmer.

After an alarm the user keys in their access code to silence the alarm, but cannot reset the system. The system generates a four digit code number and displays it on the keypad. The user calls the central station and tells them the number shown on the keypad display. The central station verifies the user's identity, then enters the code number into a special programmer. The programmer generates a 'Reset Code', which the central station gives back to the user. The user then enters the 'Reset Code' at the keypad to reset the system.

Note: To delete a CSID code key in "0000" over the existing code.

Setting Time and Date (Command 51)

The system has an internal clock/calendar which uses to date stamp the log print-out. To set the system's clock/calendar to the correct time and date:

1. Enter programming mode (if you are not already there).
2. Key in 51✓ at the keypad.
The display shows the current date, for example: D04 M11 Y99
3. Key in two digits for the day number and press ✓. Use leading zeros for the first nine days of the month.
4. Key in the two digits for the month number and press ✓. Use a leading zero for January to September.
5. Key in the two digits of the year and press ✓.
The display shows the current time, for example: H12 M26
6. Key in two digits for the hours of the day and press ✓. Use the 24-hour clock.
7. Key in two digits for the minutes and press ✓.
The keypad sounder gives a double "bleep" and the display shows

“Installer Mode”. The system sets its internal clock/calendar to the time you have given it.

Abort Reset (Command 53)

Option 0 ensures that reset after abort is the same as system reset (see Command 33).

Option 1 enables customer reset after an abort if they unset the system within 90 seconds of the alarm.

Level B Final Exit Response (Command 60)

Command 60 controls how the system will treat Final Exit zones in Part Set Level B. When the command option is set to 0 any Final Exit zones included in Part Set B will continue to act as Final Exit zones during Part Set B. When the option is set to 1 any Final Exit zones included in the Part Set B will act as Normal Alarm zones while the system is Part Set.

Level B Entry Route Response (Command 61)

Command 61 controls how the system treats Entry Route zones during Part Set B. When the option is set to 0 all Entry Route zones included in Part Set B will continue to act as Entry Routes during Part Set B. When the option is set to 1 any Entry Route zones included in the Part Set B will act as Final Exit zones while the system is Part Set.

Level B Exit Mode (Command 62)

Command 62 specifies the exit mode for Level B.

Option 0 makes the keypad sounders and any internal sounders give a low tone when entering Part Set Level B. Use command 65 to select the exit time.

Option 1 makes the Part Set B Instant Set (no exit tone)

Option 2 makes the Part Set B Silent Set. Use command 65 to program the Exit time.

Level B Alarm Response (Command 63)

Command 63 specifies the alarm response for Part Set B.

Option 0: Keypad sounders only

Option 1: Internal sounders and keypad sounders

Option 2: Local alarm (internal and external sounder only)

Option 3: Full alarm (communication and internal/external sounders).

Level B Entry Time (Command 64)

This command sets the entry time for Level B. See “Programming Commands” for options.

Level B Exit Time (Command 65)

This command sets the exit time for Level B. See “Programming Commands” for options.

Output Programming (Commands 81, 82 and 83)

The system has three transistorised, high current, programmable outputs. Command 81 programs output 1, command 82 programs output 2 and command 83 programs output 3. All three commands take a single following digit describing the function.

Note: The outputs are a “pull down” type that provide negative applied control signals. The outputs are +12V when inactive, and 0V when active.

Output Type

Bell	(Key in 0) In an alarm the system operates the output. The output is controlled by the bell delay and bell duration timers (see Commands 41 and 42).
EE Follow	(Key in 1) This output is active when the entry or exit time starts and deactivates at the end of the entry/exit time, or if the entry/exit time is terminated. The output can be used for a separate entry/exit buzzer. Note that the output does not give a tone during part set if the exit mode is silent set or instant set.
Armed lamp	(Key in 2) The output is active continuously while the system is full or part set.
Set Latch	(Key in 3) This output is active when the system is set and deactivates when the system is unset or an alarm condition occurs. The output will also activate for one second when a reset is performed or the control unit leaves programming mode. In addition, the output is active during a walk test.
Shock Reset	(Key in 4) This output is used to reset shock sensors, (for example the ‘Viper’). The control unit triggers the output at the start of the exit period. The output remains active for a fixed time of five seconds.
Walk Test	(Key in 5) This output is active during both engineer and user walk test and in the period between silencing the system and resetting the system. This output type is used on movement detectors which have the facility to switch off the walk test LED in any state other than a walk test.

Ready Lamp	(Key in 6) This output is active when the system is in Day, and if there are no faults. The output is inactive when the system is full or part set, during any alarm, or if a circuit fault prevents setting. Note that the output will also be active when the control unit is in programming mode.
24 Hour alarm	(Key in 7) This output will become active if a zone designated as '24 Hours' is violated. The output deactivates when the system is disarmed.
Strobe	(Key in 8) In an alarm the system operates the output. The output remains active until the user disarms the system.
Smoke Reset	(Key in 9) This output is designed to be connected to low voltage smoke detector reset terminals. The control unit operates the output for 3 seconds when the system is reset after any alarm has occurred.

Dual Ply Entry Warning (Command 86)

If users habitually exceed the entry time use option 1 to add a 30 second extension during which the internal sounders give a warning tone. The extension applies to both Full and Part setting. Note that if users exceed the dual ply entry warning the system gives a full alarm.

Use Option 0 (default) to disable Dual Ply Entry.

Keypad Dual Key PA (Command 87)

This command allows users to raise a PA alarm by pressing keys 1 and 3 together on the keypad. Use option 1 to enable this facility, option 0 to disable it. Note that this command also enables PA from keyswitches (See "9928 Installation Guide".)

Alarm Confirmation (Command 89)

Option 1 allows you to program the 9750 for Alarm Confirmation (verified alarm), if required by your local Police Intruder Alarms Policy. When a detector causes an alarm the control unit activates Channel 3 (Burg). If a second detector is triggered then the control unit activates the programmed alarm confirmation channel.

Option 0 disables Alarm Confirmation.

Commands 90 - 97, See "5. Testing"

Load Full Defaults (Command 98)

Use this command to load default values for all commands.

1. Enter programming mode (if you are not already there).

2. Key in 98 ✓ at the keypad.

The display shows:

Load Defaults

3. Press 1. (You can press ✕ to stop the procedure if you change your mind at this stage.)

4. Press ✓.

The system loads the factory default command values, erasing all previously programmed values.

Notes: The log is protected and cannot be erased by the Installer.

Leave Programming Mode (Command 99)

To leave programming mode:

1. Key in 99 ✓ at the keypad.

The display shows:

Exit Eng?

2. Press ✓.

The display shows:
and after a few seconds the control unit
resets itself and returns to user mode.

Checking System

If any 24 hour, Fire, PA or Technical zones are active when you try to leave programming mode then the keypad gives an error tone and displays all the faults.

Clear the faults shown on the display and press ✓. Repeat steps 1 and 2 and the control unit should leave programming mode.

Call Mode (Command 101)

You may select one of the following call modes:

Disabled (0) The control unit does not use any communications.

Single (1) Reports to a single telephone number (see Command 115) with a single account number (see Command 117).
Operation: The system dials the number and attempts to connect with the remote receiver. If it fails, it closes down and then re-attempts to connect up to a maximum of 15 times.

Alternate (2) Reports to one of two programmed telephone numbers (see Commands 115 and 116).
Operation: The system dials the first telephone number and attempts to connect to the remote receiver. If it fails, it will

then close down and dial the second telephone number and attempt to connect to the remote receiver. If received and acknowledged on this attempt, the system will close down and the alarm transmission will be complete. If the system fails to connect to the second telephone number, it will close down again and re-attempt to connect to the first telephone number. The system will continue to shuttle between the two numbers up to 15 times.

Dual (3)

Reports to two different receiver numbers (see Commands 115 and 116).

Operation: The communicator dials the first telephone number and attempts to connect to the first central station. If received and acknowledged, the communicator dials the second number and attempts to transmit to the second central station. If received and acknowledged by the second number, the communicator will close down and the alarm transmission will be complete. If calls to the first number fail, then the communicator attempts to call the second number. If the communicator fails to connect to the second telephone number, it will close down again and re-attempt to connect to the first telephone number. The communicator will continue to shuttle between the two numbers, calling each number up to 15 times, until it has successfully called both numbers.

Note: Dual reporting does not work with SIA or CID reporting formats.

Reporting Type (Command 103)

The system offers four message formats:

- | | |
|----------|---|
| Option 0 | Scancom Fast |
| Option 1 | Contact ID |
| Option 2 | Scancom SIA Level I |
| Option 3 | Scancom SIA Level II (does not send time and date). |

Line Fail Response (Command 106)

This command lets you program the system to respond with either audible or silent alarms when the system detects a fault on an attached telephone line. The exact response depends on whether the system is set or unset, as follows:

- | | |
|--------------|---|
| Disabled (0) | The control unit does not monitor the telephone line. |
| Audible (1) | If the system is unset then the system logs the event. The keypad produces a short audible tone every minute. |

Entering a valid access code silences the sounders and the displays indicates a telephone line fault. The system can be set again with the line fault present.

Note: Audible response is the NACOSS recommendation for line fault.

If the system is set then the control unit logs the event but the keypads do not give any tone or display. The control unit cancels any programmed bell delay if the line is out of order when an alarm occurs.

Silent (2)

If the system is unset then the keypad display indicates a telephone line fault and the control unit logs the event. The system may be set again with the line fault present.

If the system is set then the keypad does not give any display or tone but the control unit does log the event. The system cancels any programmed bell delay if the line is out of order when an alarm occurs.

Line Integrity Checking (Command 107)

Integrity off (0)

The control unit does not perform any line integrity checks.

Integrity on (1)

With this option enabled, the system seizes the telephone line 12 hours after the last call and dials the first digit of the first programmed telephone number. If the dial tone disappears, then the line is good and the system hangs up and resets the 12 hour timer. If the dial tone does not disappear (the out of service tone is on the line), then the system triggers the programmed Line Fail Response.

Dynamic Test (Command 108)

In dynamic testing the system makes a test call 24 hours after the last communication. Select option 0 to disable dynamic test calls. Select option 1 to enable dynamic test calls.

Three Way Call - UK only (Command 109)

To use Three Way Call you must set the dialling type to DTMF (see command 102) and make sure that the BT Network Services Option of 'Three Way Calling' is available on the telephone line to which the communicator is connected.

Three way off (0) Disabled

Three way on (1) Three Way Call.

Operation: If the control unit triggers the communicator and the communicator detects Off Hook or Incoming Ringing, the communicator then sends a 80 ms trigger

(which represents the “R” or Recall button on a telephone) which is detected by the exchange as a request for a new clean line. With the new line available, the communicator then attempts to connect to the pre programmed receiver number.

Download Mode (Command 110)

The 9750 can be programmed from a PC using <Downloader> software. You can connect the PC to the control unit over the telephone network.

Key in 110 ✓ ✓ to manually accept a call from the PC.

You will also need to use commands 112, 113. (Note that Secure callback does not work with this option.) The control unit will leave command 110 if <Downloader> does not make a call within 30 minutes.

While the control unit is connected to the PC you can upload its programming configuration into the <Downloader> in order to inspect it. Using <Downloader> you can change the configuration and then transmit the new configuration back to the control unit. If you do not wish to change the configuration you can simply monitor the state of the control unit and zones from the PC.

Use command 114 if you want the control unit to answer incoming calls from <Downloader> without an engineer being present.

Rings to Answer (Command 112)

Use this option to set the number of rings that the system waits before answering an incoming call from the remote PC. See “Programming Commands” for the available options.

Answer on One Ring (Command 113)

(Answer phone defeat) Use this feature if the alarm system shares a line with other equipment.

One ring off (0)	Disabled
One ring on (1)	<Downloader> “warns” the alarm system that a call is coming by ringing the alarm system number, waiting for between one and two rings and then hanging up. The alarm system now knows to expect a call within the next 10 to 90 seconds. <Downloader> then rings the alarm system again, within 10 to 90 seconds. The alarm system answers after the first ring.

Note: When using “Answer on 1 Ring” set the number of rings in “Rings to Answer” (C112) to a higher number than that used by the equipment sharing the telephone line with the alarm system. If you do not, then the other equipment will never answer any incoming calls.

Access Mode (Command 114)

This function allows you to provide extra security when a remote PC is dialling into the system. Once the PC is connected to the system then the <Downloader> has access to all system programming commands. If you wish to provide secure access then either use Option 0 or Option 1 below. Alternatively you can use command 110 if you want an engineer present to provide access for a remote PC connection to the panel. Please note that you cannot use secure callback with command 110.

Option 0 Call Out Only.
Operation: Someone must start a call to the remote PC manually using Command 0 in User Mode. User command 0 calls the first <Downloader> telephone number (see command 118).

Option 1 Secure Callback.
Operation: When the remote PC calls, the system waits for the set number of rings (see command 112) and then answers. The remote PC sends a panel ID, the <DOWNLOADER> software version, and indicates which of the two Downloader Telephone Numbers to use (see commands 118/119). The system checks that the remote PC is sending the correct panel ID, and is using the correct <DOWNLOADER> software version. If these items don't match then the system hangs up. If the items do match then the system hangs up and, after a short delay, the system seizes the telephone line and calls the PC using the indicated Downloader Telephone Number.

Note: Secure Call Back must be Disabled (Default) until the first "attended" upload has been performed. This first upload can be carried out either using command 110 option 1, or using command 114 option 0.

Option 2 Unattended Mode.
Operation: The control unit answers as soon as the number of rings set in commands 112 and 113 have elapsed.

Note: The <Downloader> operator can choose to use Secure Callback, even though the alarm system is programmed for Unattended Mode.

Communicator Telephone Numbers (Command 115/116)

Use this command to store the telephone numbers that the communicator will use. The system will accept one telephone number if you choose Single call mode in command 101, or two telephone numbers if you select Alternate or Dual call mode.

The system can store telephone numbers up to 31 digits long.
You can use the A key to insert a pause (four seconds).

To enter a number:

1. Enter programming mode (if you are not already there).

2. Key in 115 (or 116) ✓ at the keypad.

The display shows (for example): 115:Tel No 1_

3. Press ✓.

4. Key in the digits of the number. If necessary press D to move the cursor to the left to edit or delete the number. Press C to move the cursor to the right.

The display shows (for example): 115: 1234_

5. Press ✓.

The keypad gives a double beep and the system stores the number.

Account Number (Command 117)

With SIA Format the system can report alarms using a six digit account number.

Use leading zeros to pad the account number to the correct length if necessary, for example account 1234 would be 001234.

Downloader Telephone Numbers (Commands 118/119)

Use this option to program up to two separate, 31-digit telephone numbers. When a connection has been made, the remote PC operator selects the telephone number which the control unit will call back to (for example home or office).

You can use the A key to insert a pause (four seconds).

To enter a number:

1. Enter programming mode (if you are not already there).

2. Key in 118 (or 119) ✓ at the keypad.

The display shows (for example): 118: DL Tel No 1_

3. Press ✓.

3. Key in the digits of the number. If necessary press D to move the cursor to the left to edit or delete the number. Press C to move the cursor to the right.

The display shows (for example): 118: 1234_

4. Press ✓.

The system stores the number.

Fast Format Channels (Command 121)

If you selected Fast Format reporting type in command 103 then you can use command 121 to allocate one of the following events to each of the 8 channels:

0	Not used	8	Detector Low Battery
1	Fire	9	Supervision Loss
2	PA	X1	RF Jamming
3	Burglar	X2	AC Fail
4	Open/Close	X3	Tamper Alarm (Day tamper)
5	Alarm Abort	X4	Open (see note 1)
6	Technical Alarm	X5	Close (see note 1)
7	Alarm Confirmation	X6	Zone Omitted (see note 2)

Notes: 1. X4 Open and X5 Close provide the same functions as 4 Open/Close, but on two separate channels.

2. X6 Zone omitted - the control unit sends this signal for five seconds when a user omits a zone.

Report Restorals (Command 123)

This option is only available if you have selected Scancom Fast format (C103).

Restore off (0) The system does not communicate restorals.

Restore on (1) Enabled. The system will communicate restorals.

Country Defaults (Command 126)

Use this command to select the country and PTT defaults. Note that the system will ask for confirmation and you must press 1 ✓ to end the command. Note that this command loads default access codes and programming options. See “Programming Commands” for details of the options available.

Report Mode (Command 131)

SIA reports are called ‘Telegrams’. Each telegram contains the site identification number (normally six digits long) and relevant event information. The amount of information reported depends on the SIA mode you select: Basic, Intermediate, or Full. Figure 23 shows the types of report for each mode. Use the table to decide which mode is appropriate for the installation.

Option 0 = Basic

Option 1 = Summary

Option 2 = Intermediate

Option 3 = Full

	Basic	Summary	Intermediate	Full
Fire	Y	Y	Y	Y
Panic	Y	Y	Y	Y
Duress	Y	Y	Y	Y
Keypad PA	Y	Y	Y	Y
Burglar	Y	Y	Y	Y
Exit time out	Y	Y	Y	Y
Sensor tamper	Y	Y	Y	Y
Sensor tamper restore	Y	Y	Y	Y
Periodic test report	Y	Y	Y	Y
PA telecommand	Y	Y	Y	Y
Program mode start		Y	Y	Y
Program mode end		Y	Y	Y
Zone omit		Y	Y	Y
Fire restore		Y	Y	Y
PA restore		Y	Y	Y
Burglar restore		Y	Y	Y
Tamper user code		Y	Y	Y
TA restore		Y	Y	Y
TA		Y	Y	Y
Password defaults loaded			Y	Y
System tamper			Y	Y
Sounder tamper			Y	Y
Sounder tamper restore			Y	Y
Expander tamper			Y	Y
Expander tamper restore			Y	Y
Arm			Y	Y
Disarm			Y	Y
Reset			Y	Y
Tamper in day			Y	Y
Tamper keypad			Y	Y
Transmitter battery trouble			Y	Y
Jamming			Y	Y
Supervision fail			Y	Y
Download success			Y	Y
System tamper restore				Y
User code changed				Y
User code deleted				Y
Time date reset				Y
Telephone number 1 fault				Y
Telephone number 1 restore				Y
AC fail				Y
AC restore				Y
Low battery				Y
Low battery restore				Y
Aux trouble				Y
Aux restore				Y

Figure 28. SIA Telegram Reports

The system also provides a “custom” mode which allows any combination of event information. However, you must use <Downloader> to create the combination required.

SIA alarm transmissions will take considerably more telephone time than Scancom Fast format since the system transmits extended alarm data to the central station.

Modem Tone Format (Command 132)

If you select SIA format in command 103 then you can use command 132 to select the modem tones used by the plug-on communicator. Check with your central station what type of modem tones are required.

Option 0 Bell 103 tones.

Option 1 300 Baud FSK CCITT V21 modem tones.

Contact ID Options (Command 143)

If you selected Contact ID in command 103 then use command 143 to select the types of contact ID messages that will be sent.

Option 0 Mode Basic, comprises the messages shown in Fig 28 in the “Basic” column.

Option 1 Mode Basic + Restore. With this option the system still sends the messages listed for Option 0, but also sends restore for Burglar alarm, fire, PA and Tamper.

If the keypad display shows “Custom” when you enter command 143 then <Downloader> has been used to program this command. Using <Downloader> you can select any of the Basic messages from Option 0, plus the following:

Technical alarm	Engineer on site	Engineer off site
Log downloaded	Tamper panel	Tamper expander
Keypad tamper	Tamper sounder	RF jamming
RF supervision fail	RF zone low batt.	AC fail
Change time	Plug-on line fail	Battery missing
Battery fault	Abort	

5. Testing

Reading the Log (Command 90)

The control unit keeps a 250 event log of recent events. Each event is represented by a two digit code, shown on the next page. To review the event log, make sure the system is in programming mode, then:

1. Key in 90✓.
The display shows the most recent event in the log. For a list of the log codes see the next page.
2. Key in 1 to show earlier events or 3 to see more recent events.
3. Press ✓ to toggle between the event message and the event time.
4. Press ✕ to leave the log.

The table below and on the next page shows all the messages that can appear in the event log.

Note that neither the Installer nor the user can erase the log.

In the log user codes are represented by numbers as follows:

U00	Installer	U06	User code 6	U13	Keyswitch
U01	User code 1	U07	User code 7	U14	Remote Rst
U02	User code 2	U08	User code 8	U15	Download
U03	User code 3	U09	Duress code		
U04	User code 4	U11	For future use		
U05	User code 5	U12	Telecommand		

Keypad and Event Log Displays

Keypad

EEProm Fail,
Codes Defaulted
System Startup
System Tamper
System Tamp Rst
Sounder Tamper
Sounder Tamp Rst
Unn On-Site
Unn Off-Site
Unn Change Unn
Unn Delete Unn
Unn L# Set
Unn L# UnSet
U13 L# Set
U13 L# UnSet
System Rearmed

5. Testing

Unn Znn Omit
Unn Znn Unomit
Fire Znn Alarm
Fire Znn Rstr
Fire Znn Reset
PA Znn Alarm
PA Znn Rstr
Unn System Unset
PA Knn Alarm
Burg Znn Alarm
Set Fail Znn
Burg Znn Rstr
Tamper Znn
Knn Missing
Knn Restore
Knn Tamper
Knn Excess Keys
Low Bat Znn
Low Bat Znn Rstr
RF Jamming
RF Jamming Rstr
RF Sup Fail Znn
RF Sup Rstr Znn
Tel Line Fault
Tel Line Rstr
Comms Fail
AC Fail
AC Restore
Low Battery
Low Batt Rstr
Batt Missing
Batt Missing Rstr
Batt Load Fail
Aux DC Fail
Aux DC Fail Rstr

Engineer Walk Test (Command 97)

Allows the engineer to test all devices on the system.

1. Enter programming mode.

2. Key in 97 ✓

The display shows:

97: Walk Test

3. Open and close each alarm and tamper contact in turn.

The system gives a chime tone each time you open and close a detector contact. The displays shows: "A:Zone:" and the zone number of every detector you have tested (note that the display displays each zone number for one second, in sequence). If you also test the tampers on each zone the display shows the letter "T" against each zone number. .

4. Press ✕ to stop the walk test.

Note that the Engineer's walk test allows you to test **all** zones including PA zones, zone tampers, and control unit and bell tampers. The user's walk test does not allow you to test PA, Fire, 24Hr, Technical zones, or tampers.

5. Testing

Index

Symbols

24 hour alarm	47
24 hour zones	38

A

Access codes	6
restoring	36
Access mode	52
Account numbers	53
Alarm Abort	
description	42
Alarm Confirmation	47
Alarm response	45
Alternative reporting	48
Answer on one ring	51
Armed lamp	46
Arming station	4
fitting	13
Assign comms channels	54
Auto re-arm	43
Auxilliary	
output	7

B

Basic SIA	54
Battery	7
fitting	26
Bell	46
current	7
delay	43
duration	43

C

Cable entries	14
Call modes	48
Central station	52
Channels	
for communications	49
Chime	39
Command	
01 - 16	37
101	48
103	49
106	49
107	50
108	50
109	50
110	51
112	34, 51
113	34, 51
114	52

115, 116	52
117	53
118, 119	53
121	35, 54
122	54
126	54
131	54
132	56
143	56
20	40
22	40
23	40
25	40
26	41
27	41
28	41
30	41
33	41
34	42
35	42
36	42
37	42
38	42
39	42
40	43
41	43
42	43
43	43
44	43
45	43
50	44
51	44
53	45
60	45
61	45
62	45
63	45
64	45
81, 82 and 83	46
86	47
87	47
89	47
90	57
97	59
99	48

Comms channels

fast format	54
-------------------	----

Communicator

approval	21
built in	20
connecting	24
installing	20
output	7
outputs	25
plug by	1
fitting	24
wiring	25

Contact ID	56
Continuous Sounder	40

Control Unit

diagram	1
---------------	---

Control unit

fitting case	11
fitting PCB	11

Controls and display	3
----------------------------	---

Country defaults	54
------------------------	----

CSID	44
------------	----

D

Defaults	30
restoring	37
Dial	
pause	53
Dimensions	7
Double Knock	39
Download mode	51
Downloader telephone numbers	53
Dual ply entry	47
Dual reporting	49
Duress code	6, 29
Dynamic test	50

E

Engineer code	29
changing	40
Entry route	38
Entry route response	45
Entry time	43, 45
Entry/exit follow	46
Entry/Exit tone	43
Exit fault external sounders	41
Exit mode	42, 45
Exit terminate button	16, 42
Exit time	43
Expander connection	17

F

Fast Format	49, 54
Final door set	43
Final exit	38
Final exit response	45
Fire	37
First circuit response	42
Four wire CCL	17
Full set	5, 6
Full SIA	54
Fuse	14
Fuses	7

H

Humidity	7
----------------	---

I

Inputs	7
Installation overview	11

K**Keypad**

addressing	15
backlight	15
backplate	12
connection	16
current	7
displays	41
dual key PA	47
fitting	12
tamper	12
Keyswitch connection	19

L

Learning	5
Line Fault	
Audible displayed alarm	49
input	7
response	21, 49
silent	49
Tamper	49
tamper	50
Line integrity	20, 50
Line monitor	20
Local sounder delay on entry	41
Log	57
printing	57
viewing	57
Loudspeaker	7
Loudspeaker chime	40

M

Mains connection	14
Modem tone format	56

N

Normal alarm	38
Not used	37

O

Omit	6
Omit allow	38, 39
Operating temperature	7
Output	
communicator	7
programming	46
type	46
using	18

P

PA	5, 10
PA reset	42
Panic Alarm	5, 10, 37
Part set	6
Part set B	39
Pause	53
PBX	21
Personal Attack	5, 10
PIR	5
Power	7
Programming commands	29
Programming mode	29
entering	27
leaving	36, 48
re-entering	36

R

Ready lamp	47
Remote PC	20
REN	22
Report mode	54
contact ID	56
fast format	54
SIA	54
Report restorals	
Contact ID	56
fast format	54
Reporting type	49
Reset	
after abort	45
engineer	36
first stage	36
RedCare	7
remote	44
shock	46
system	41
tellback	40
Rings to Answer	51

S

Secure callback	52
SELV	23
Set latch	46
Set with Omit	6
Shock analyser	38
Shock reset	46
SIA	54
Silent or audible PA	41
Single reporting	48
Smoke detector	5
Smoke reset	47
Soak Test	39

Sounder connection	16
Specification	7
Start up	27
Status display	41
Strobe	47
Summary SIA	54
System reset	41

T

Tamper communication	42
Technical	38
Telecommand	5, 10
Telegrams	54
Telephone Line	20
connection	23
sharing	23
Telephone numbers	52
Tellback	7
Tellback reset	40
Test receiver	10
Test transmitter	5
Testing	57
Three way call	20, 50
Time and date	44
Timed or terminate	42
TNV	23
Transmitter	5, 10

U

Universal transmitter	5, 10
User codes	29

W

Walk test	46, 59
Weight	7

Z

Zone	
attributes	38
description	5
programming	37
types	37
wiring	17

Cooper Security Ltd
Security House
Xerox Business Park
Mitcheldean
Gloucestershire
GL17 0SZ

Product Support (UK) Tel: (09068) 616343
Between 09:00 and 17:30 Monday to Thursday, 09:00 to 17:00 Friday
(CALLS CHARGED AT 60p PER MINUTE)
Product Support Fax: (01594) 545401

Part Number 496478 Issue 1